

We design polymers.

Discover our world of  
liquid polybutadienes.



.....  
WELCOME TO THE WORLD OF  
LIQUID POLYBUTADIENES  
.....

## **POLYVEST®**

---

.....  
**POLYVEST®**  
LIQUID POLYBUTADIENES  
.....

PAGE	CONTENT
<b>5 - 6</b>	<b>THE WORLD OF LIQUID POLYBUTADIENES</b> Benefits at a glance
<b>7 - 15</b>	<b>PRODUCT PORTFOLIO</b> Analytical methods
<b>16</b>	<b>SUSTAINABILITY ASPECTS</b>
<b>17 - 18</b>	<b>APPLICATION AREAS</b>
<b>19</b>	<b>PHYSICO-CHEMICAL PROPERTIES</b>
<b>20</b>	<b>GENERAL INFORMATION AND PRODUCT SAFETY</b>
<b>21</b>	<b>CONTACT</b>

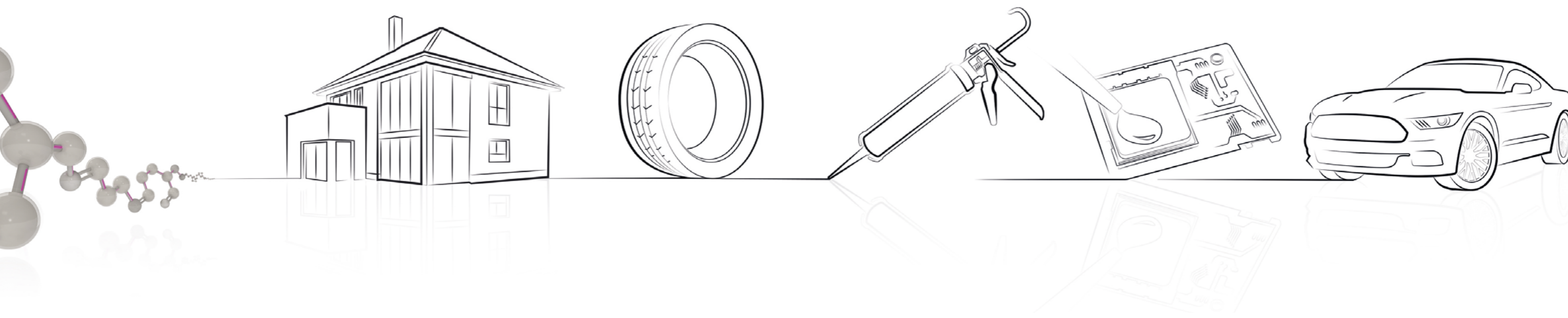

**For more than 50 years, Evonik's Coating & Adhesive Resins Business Line has been offering POLYVEST®, a range of stereospecific, low viscous and unsaponifiable liquid polybutadienes with different chemical compositions.**

Based on their characteristic microstructure, all POLYVEST® grades exhibit an excellent reactivity and can be used for a broad variety of applications. The unsaturated polymer backbone of all POLYVEST® grades offers the opportunity for various crosslinking options, like sulfur curing and oxidative drying. In addition, the functional moieties of POLYVEST® HT and POLYVEST® MA provide further options for crosslinking and make polymer modification feasible. Due to its rubber-based nature, POLYVEST® ST is perfectly suited as a reactive plasticizer in tire and mechanical rubber goods applications.

## BENEFITS AT A GLANCE

- Low viscosity
- Excellent chemical resistance to acids and bases
- High water resistance
- Excellent electrical insulation properties
- Low temperature flexibility
- Low moisture and oxygen permeability

## POLYVEST® PRODUCT RANGE

- **POLYVEST® 110 & 130** - non-functionalized liquid polybutadienes
- **POLYVEST® MV** - mid vinyl content, non-functionalized liquid polybutadiene
- **POLYVEST® MA** - maleic anhydride-functionalized liquid polybutadienes
- **POLYVEST® HT** - hydroxyl-terminated liquid polybutadiene
- **POLYVEST® ST** - silane-terminated liquid polybutadiene
- **POLYVEST® MAT** - methacrylate-terminated liquid polybutadiene

# POLYVEST® PRODUCT PORTFOLIO

## Product Range

POLYVEST®		110	130	EP* MV	MA 75	EP* MA 100	HT	ST-E 60	EP* MAT
<b>Specifications</b>									
Viscosity at 20°C	[mPa s]	700 - 860	2,700 - 3,300	5,000 - 7,000	6,000 - 9,000	-	-	7,500 - 15,000	6,000 - 9,000
Viscosity at 30°C	[mPa s]	-	-	-	-	9,000 - 16,000	4,000 - 5,500	4,000 - 7,500	-
Acid Number	[mg KOH/g]	≤ 0.3	≤ 0.3	≤ 0.5	70 - 90	95 - 115	-	-	-
Hydroxyl Number	[mg KOH/g]	-	-	-	-	-	44 - 51	-	-
Peroxide Number	[mval/kg]	≤ 10	≤ 10	≤ 10	-	-	-	-	-
Water Content	[mg/kg]	-	-	-	-	-	-	≤ 500	-
Gardner Color	-	-	-	-	≤ 2.5	-	-	≤ 1.5	-
<b>Typical Data</b>									
Molecular Weight, M <sub>n</sub>	[g/mol]**	approx. 2,600**	approx. 4,600**	1700 - 2700 **	approx. 2,900**	approx. 2,900**	approx. 2,900***	approx. 3,200***	approx. 3,000***
Iodine No.	[g Iod/100g]	420 - 480	420 - 480	approx. 400	380 - 420	350 - 390	420 - 440	-	-
Density at 20°C	[g/cm <sup>3</sup> ]	0.90 - 0.92	0.90 - 0.92	0.89 - 0.92	approx. 0.95	approx. 0.96	0.90 - 0.92	0.8 - 1.0 at 25°C	-
Gardner Color	-	≤ 1	≤ 4	≤ 1	-	≤ 3.0	≤ 1	-	approx. 6
Flash Point	[°C]	approx. 180	approx. 200	> 245	approx. 300	approx. 260	approx. 215	-	-
Ignition Temperature	[°C]	approx. 360	approx. 350	approx. 360	approx. 360	approx. 375	approx. 375	-	-
Pour Point	[°C]	approx. -55	approx. -50	approx. -27	approx. -25	approx. -18	approx. -18	-	-
Glass transition Temperature, T <sub>g</sub>	[°C]	approx. -102	approx. -104	approx. -70	approx. -95	approx. -100	approx. -80	approx. -80	approx. -83
Mean functionality	-	-	-	-	-	-	approx. 2.4 (-OH)	approx. 1.5 (Silane)	2.4 (Methacrylate)
Residue on Ignition at 950°C	[wt.%]	-	-	-	-	-	-	1.0 - 3.5	-

Note: all POLYVEST® grades are supplied in liquid viscous form.

\* EP = Experimental Product. The indicated properties are target values and may be subject to change during the upscaling process.

\*\* = Determination via GPC calibrated with polystyrene standard.

\*\*\* = Determination via GPC calibrated with polybutadiene standard.

## ANALYTICAL METHODS

### Viscosity

Determination according to DIN EN ISO 3219.

### Acid Number

Determination according to DIN EN ISO 2114.

### Hydroxyl Number

Determination according to DIN 53 240-2.

### Peroxide Number

Determination according to DGF-method: C-VI-6a (84).

### Iodine Number

Determination according to DIN 53 241.

### Molecular Weight, M<sub>n</sub>

Determination via GPC according to DIN 55 627-1, calibrated either with polystyrene or polybutadiene standards (please see footnote for details)

### Density

Determination according to DIN ISO 2811-1 (at 20°C).

Determination according to DIN 51757, method 4 (at 25°C).

### Flash Point

Determination according to DIN EN ISO 2719.

### Gardner Color

Determination according to DIN EN ISO 4630.

### Ignition Temperature

Determination according to DIN 51 794.

### Pour Point

Determination according to DIN ISO 3016.

### Glass Transition Temperature, T<sub>g</sub>

Determination according to DIN EN ISO 11 357-1.

### Water Content

Determination according to DIN 51777-2.

### Residue on Ignition at 950°C

Determination according to ASTM D 6740.

## POLYVEST® 110

POLYVEST® 110 is a stereospecific, low viscous and unsaponifiable liquid polybutadiene manufactured using Ziegler-Natta polymerization. Due to its microstructure and high 1,4-cis double bonds, this apolar and hydrophobic polybutadiene is a highly reactive and crosslinking binder providing benefits to broad fields of applications.

### Microstructure

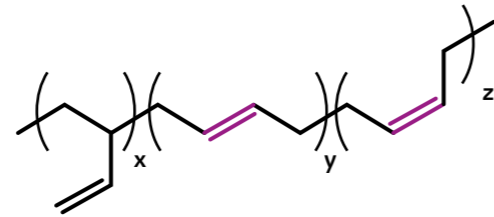

x = 1,2-vinyl double bonds[%]: ~ 1%  
 y = 1,4-trans double bonds[%]: ~ 24%  
 z = 1,4-cis double bonds[%]: ~ 75%

### MOST COMMON APPLICATIONS

#### Adhesives & sealants



#### Binder for dusty and dry quartz sand



#### Electrical insulation & potting compounds



#### Flexible printing plates

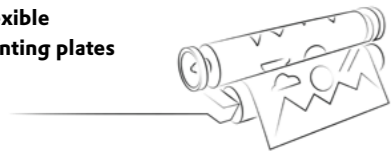

#### PU foam release agent



### PERFORMANCE CHARACTERISTICS

- Excellent chemical resistance to acids and bases
- High water resistance
- Excellent electrical insulation properties
- Low temperature flexibility
- Good compatibility with hydrocarbon resins, rosin resins and zinc resonates
- Good solubility in aliphatics, aromatics and ethers

### TYPICAL PROPERTIES (SELECTED)

Viscosity @ 20°C [mPa s]	700 - 860
Acid number [mg KOH/g]	≤ 0.3
Peroxide number [mval/kg]	≤ 10
Glass transition temperature [°C]	-102

## POLYVEST® 130 POLYVEST® 130 S

POLYVEST® 130 is a stereospecific, low viscous and unsaponifiable liquid polybutadiene manufactured using Ziegler-Natta polymerization with a higher molecular weight. Due to its microstructure and high 1,4-cis double bonds, this apolar and hydrophobic polybutadiene is a highly reactive and crosslinking binder providing benefits to a broad field of applications. POLYVEST® 130 S is suited as reactive plasticizer in rubber compounds and boost the winter performance of tire tread compounds.

### Microstructure

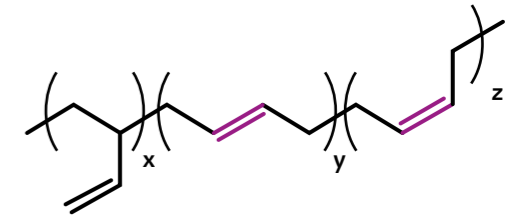

x = 1,2-vinyl double bonds[%]: ~ 1%  
 y = 1,4-trans double bonds[%]: ~ 22%  
 z = 1,4-cis double bonds[%]: ~ 77%

### MOST COMMON APPLICATIONS

#### Adhesives & sealants



#### Binder for dusty and dry quartz sand



#### Electrical insulation & potting compounds



#### Flexible printing plates

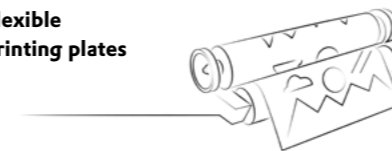

#### PU foam release agent

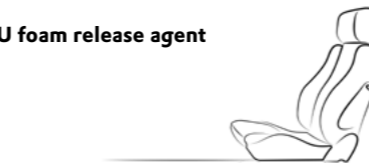

#### Tires & mechanical rubber goods



### PERFORMANCE CHARACTERISTICS

- Excellent chemical resistance to acids and bases
- High water resistance
- Excellent electrical insulation properties
- Low temperature flexibility
- Good compatibility with hydrocarbon resins, rosin resins and zinc resonates
- Good solubility in aliphatic, aromatics and ethers

### TYPICAL PROPERTIES (SELECTED)

Viscosity @ 20°C [mPa s]	2,700 - 3,300
Acid number [mg KOH/g]	≤ 0.3
Peroxide number [mval/kg]	≤ 10
Glass transition temperature [°C]	-104



## POLYVEST® EP MV

POLYVEST® EP MV is a stereospecific, low viscous and unsaponifiable liquid polybutadiene manufactured using Ziegler-Natta polymerization. Due to its microstructure and higher 1,2-vinyl double bonds, this apolar and hydrophobic polybutadiene is a highly reactive and crosslinking binder providing benefits to a broad range of applications.

### Microstructure

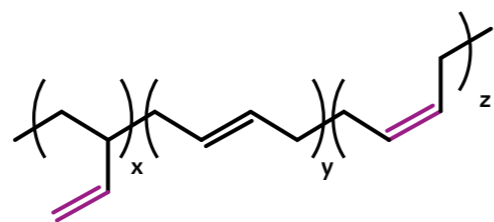

x = 1,2-vinyl double bonds[%]: ~ 61%  
 y = 1,4-trans double bonds[%]: ~ 2%  
 z = 1,4-cis double bonds[%]: ~ 37%

### MOST COMMON APPLICATIONS

#### Adhesives & sealants



#### Electrical insulation & potting compounds



#### Flexible printing plates

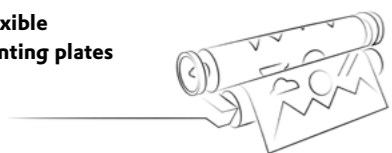

#### PU foam release agent



#### Tires and rubber compounds



### PERFORMANCE CHARACTERISTICS

- High chemical resistance
- High water resistance
- High electrical insulation properties
- Excellent low temperature flexibility
- Good solubility in aliphatic, aromatics and ethers
- Good compatibility with hydrocarbon resins, rosin resins and zinc resonates
- Possibility of UV-curing

### TYPICAL PROPERTIES (SELECTED)

Viscosity @ 20°C [mPa s]	5,000 -7,000
Acid number [mg KOH/g]	≤ 0.5
Peroxide number [mval/kg]	≤ 10
Glass transition temperature [°C]	-70

## POLYVEST® MA 75 POLYVEST® EP MA 100

POLYVEST® MA 75 is a maleic, anhydride functionalized adduct of a low molecular weight 1,4-cis liquid polybutadiene which has succinic anhydride groups randomly distributed along the polymer chains. This makes the originally apolar polybutadiene more polar and accessible for various chemical reactions. Furthermore maleic anhydride functionalized adducts differing in maleic anhydride content and viscosity are also available, e.g. POLYVEST® EP MA 100.

### Microstructure

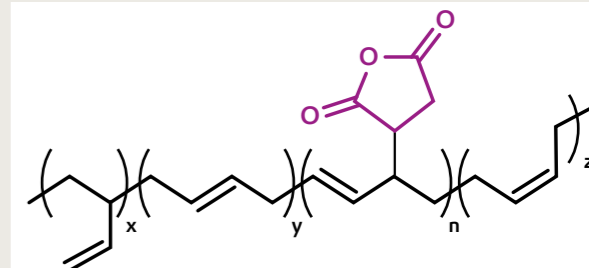

x = 1,2-vinyl double bonds[%]: ~ 1%  
 y = 1,4-trans double bonds[%]: ~ 24%  
 z = 1,4-cis double bonds[%]: ~ 75%

### MOST COMMON APPLICATIONS

#### Adhesives & sealants

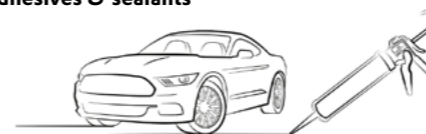

#### Electrical insulation & potting compounds



#### E-mobility

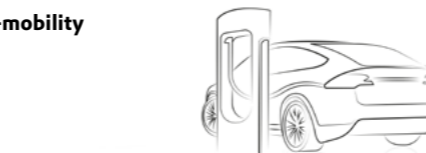

#### Tires and rubber compounds



### PERFORMANCE CHARACTERISTICS

- High chemical resistance to acids and bases
- High water resistance
- Excellent electrical insulation properties
- Low temperature flexibility
- Good compatibility with long-oil alkyd resins, rosin resins and zinc resonates

### TYPICAL PROPERTIES MA 75 (SELECTED)

Viscosity @ 20°C [mPa s]	6,000 -9,000
Acid number [mg KOH/g]	70-90
Glass transition temperature [°C]	-95

### TYPICAL PROPERTIES EP MA 100 (SELECTED)

Viscosity @ 30°C [mPa s]	9,000 -16,000
Acid number [mg KOH/g]	95 - 115
Glass transition temperature [°C]	-100

# POLYVEST® HT

POLYVEST® HT is a liquid, hydroxyl-terminated polybutadiene manufactured by radical polymerization. The polymer exhibits a highly hydrophobic polybutadiene backbone and primary hydroxyl groups that are accessible for precise chemical modification. With a hydroxyl functionality of approx. 2.4, POLYVEST® HT is used as a polyol component in various adhesive and sealant applications. POLYVEST® HT-A is our grade destined for aerospace applications.

## Microstructure

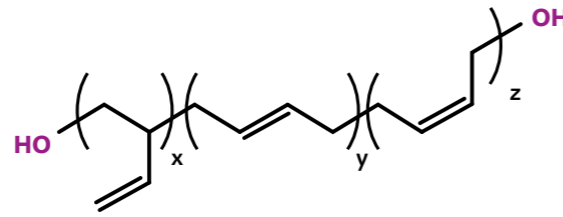

x = 1,2-vinyl double bonds[%]: ~ 22%  
 y = 1,4-trans double bonds[%]: ~58%  
 z = 1,4-cis double bonds[%]: ~ 20%

## MOST COMMON APPLICATIONS

### Adhesives & sealants



### Electrical insulation & potting compounds



### Insulated glass sealants



### Propellant for rockets



### Waterproofing membranes



## PERFORMANCE CHARACTERISTICS

- High chemical resistance to acids and bases
- Excellent water resistance
- Excellent electrical insulation properties
- Excellent low temperature flexibility
- Low moisture and gas permeability
- Good compatibility with hydrocarbon resins, rosin resins, zinc resonates, polyethers and polyetherpolyols
- Good solubility in aliphatic, aromatics and ethers

## TYPICAL PROPERTIES (SELECTED)

Viscosity @ 30°C [mPa s]	4,000 - 5,500
Hydroxyl number [mg KOH/g]	44 - 51
Hydroxyl number [meq/g]	0.78 - 0.91
Molecular weight Mn [g/mol]	~2.900
Hydroxyl functionality	~2.4
Glass transition temperature [°C]	-102

## EXPORT REGULATION

POLYVEST® HT is subject to export control measures by German Export Control Authorities. An approval by that organization may be required for export.

# POLYVEST® ST-E

POLYVEST® ST-E is a liquid, silane-terminated polybutadiene with high content of double bonds. It is manufactured by radical polymerization and further functionalization. It combines the advantages of liquid rubbers and functional silanes. Its silane functionalities enable the surface modification of hydrophilic silica fillers and, therefore, improve the dispersibility of silica in rubber compounds. Due to its rubber-based nature, POLYVEST® ST exhibits a natural fit and excellent compatibility to the rubber matrix of tire compounds.

## Microstructure

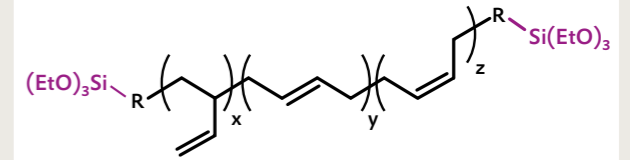

x = 1,2-vinyl double bonds[%]: ~ 22%  
 y = 1,4-trans double bonds[%]: ~58%  
 z = 1,4-cis double bonds[%]: ~ 20%

## MOST COMMON APPLICATIONS

### Adhesives & sealants

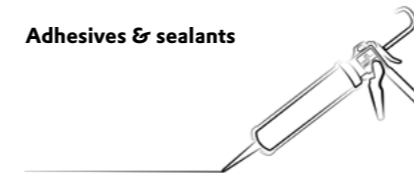

### Automotive



### Electrical insulation & potting compounds

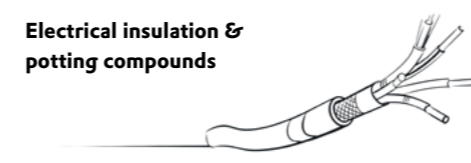

### Insulated glass sealants

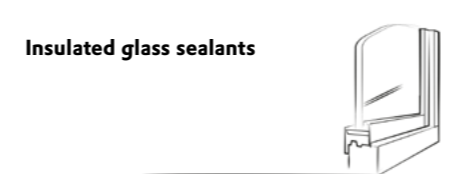

### Tires or mechanical rubber goods

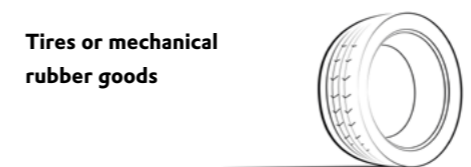

## PERFORMANCE CHARACTERISTICS

- Excellent compatibility with solid and recycled rubber
- High chemical resistance
- Good dispersion and chemical modification with high loading capacity of inorganic fillers
- High cold resistance by keeping good flexibility at low temperatures
- Good solubility in aliphatics, aromatics and ethers
- Low moisture and gas permeability
- Possibility of moisture induced curing

## TYPICAL PROPERTIES (SELECTED)

Viscosity @ 30°C [mPa s]	4,000 - 7,500
Mean molecular weight Mn [g/mol]	~3.200
Glass transition temperature [°C]	-80

# POLYVEST® EP MAT

POLYVEST® EP MAT is a liquid, methacrylate-terminated polybutadiene with a high content of double bonds. It is manufactured by radical polymerization and further functionalization. Due to its microstructure it is a highly reactive and crosslinking binder providing benefits to a broad range of applications, including UV curing technology.

## Microstructure

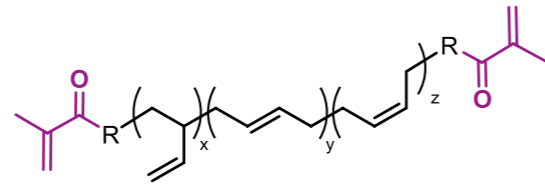

x = 1,2-vinyl double bonds[%]: ~ 22%  
 y = 1,4-trans double bonds[%]: ~58%  
 z = 1,4-cis double bonds[%]: ~ 20%

## MOST COMMON APPLICATIONS

### Adhesives & sealants

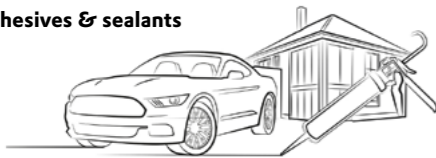

### Electrical insulation & potting compounds



### Flexible printing plates

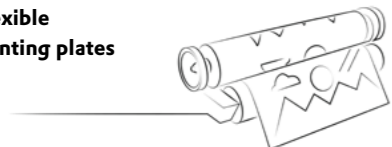

### Insulated glass sealants



## PERFORMANCE CHARACTERISTICS

- High chemical resistance to acids and bases
- High water resistance
- High electrical insulation properties
- High cold resistance
- Good solubility in aliphatics, aromatics and ethers
- Low moisture and gas permeability
- Good adhesion to various substrates

## TYPICAL PROPERTIES (SELECTED)

Viscosity @ 20°C [mPa s]	5,000 - 7,000
Molecular weight Mn [g/mol]	~3.000
Mean MA functionality	~2.4
Glass transition temperature [°C]	-83

*“ For us, doing business sustainably is not optional. It is the only way to go forward to improve life, today and tomorrow”*

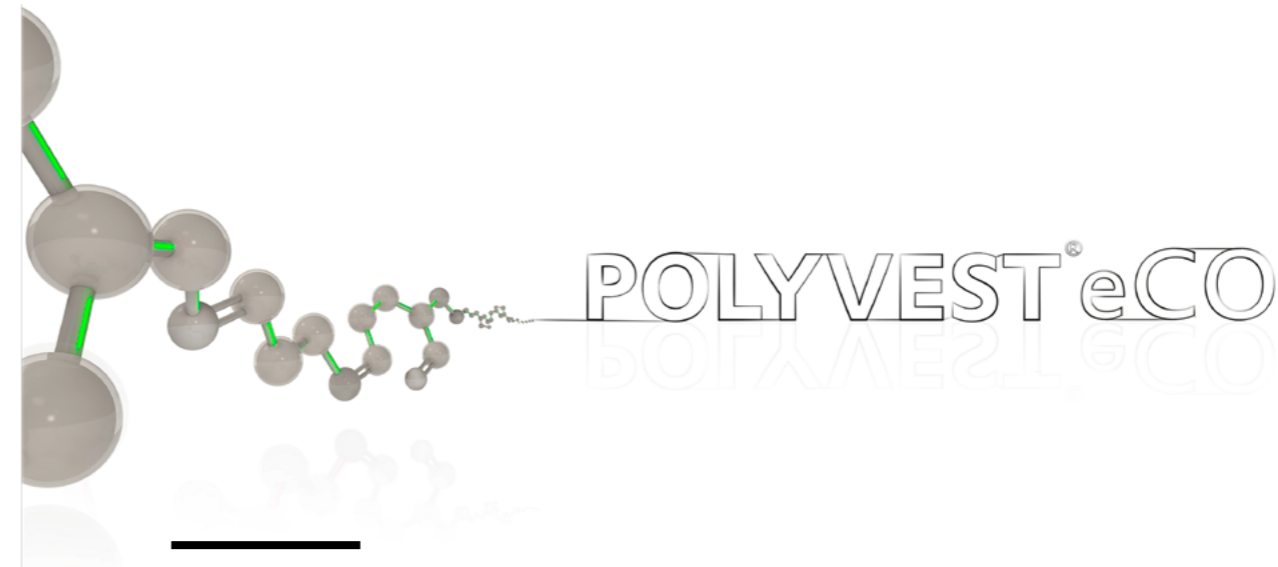

## SUSTAINABILITY ASPECTS

### SUSTAINABILITY, THE CORE OF OUR STRATEGY

Sustainability is a central element for Evonik. We provide innovative solutions that help make our lives more sustainable, more comfortable and healthier. We, the Coating & Adhesive Resins Business Line, provide products and solutions that reliably adhere to enhance a wide variety of materials, all while contributing to the conservation of resources.

### ISCC PLUS CERTIFICATION

POLYVEST® is certified by the ISCC organization (International Sustainability & Carbon Certification) to operate under their ISCC PLUS certification based on a mass balance approach. ISCC PLUS is a voluntarily certification and a trusted standard designed for the circular economy and bio-economy.

### MASS BALANCE APPROACH

The mass balance methodology allows to mix physically fossil and recycled or renewable resources in an existing infrastructure along the whole value chain while keeping track of their quantities and allocating them to specific product on a book-keeping basis.

Since the material is physically mixed, it is not possible to make a statement about the physical characteristics of the final product. However, the recycled or renewable content is verified by a third-party certificate. ISCC PLUS certification certifies the exact and complete traceability of the materials used in our production plants and confirms that the processed materials actually originate from sustainable sources.

### OUR NEW BRAND

POLYVEST® is supporting the shift towards the circular economy and bioeconomy by bringing our customers sustainable solutions under the brand name POLYVEST® eCO. The ISCC PLUS certification covers our product portfolio produced with sustainable raw materials (circular, bio-circular and bio feedstock). These certified grades do not differ in their physical and mechanical properties versus traditional grades derived from fossil-based raw materials. This allows for their use as drop-in replacements by our customers because they do not require any additional tests or investment.

**For more information regarding specific POLYVEST® grades, contact us.**

Raw material category





## APPLICATION AREAS

### POLYVEST® applications

POLYVEST®	110	130	EP* MV	MA 75	EP* MA 100	HT	ST-E 60	EP* MAT
<b>Automotive (inc. electric vehicles)</b>								
Adhesives and sealants	•	•	•	•	•	•	•	•
<b>Coatings</b>								
Air drying enhancer for vegetable oils	•	•						
Defoamers		•	•					
Impregnations	•	•	•			•	•	•
Modifier in resin systems	•	•	•	•	•	•	•	•
<b>Construction</b>								
Adhesives and sealants			•			•		•
Binder for dusty and dry quartz sand	•	•						
Binder for soil stabilization	•							
Modifier of silicone sealants				•	•			•
Insulated glass sealants						•	•	•
Joint sealants						•	•	•
Waterproof membranes and coatings						•	•	•
<b>Electronics &amp; communication</b>								
Electrical insulation and potting compounds	•		•	•	•	•	•	•
Solid and hybrid rocket propellant						•		
<b>Plastics</b>								
Cell opener for PU-Foam		•	•					
Release agents for PU-Foam	•	•	•					
<b>Polymer Modification</b>								
Chlorinated rubbers	•	•	•					
Electrocoatings	•							
Waterborne, oxidative drying binders	•							
<b>Printing &amp; Inks</b>								
Offset printing inks	•	•						
Flexible printing plates	•	•	•	•	•	•		•
<b>Rubber</b>								
Binder for recycled rubber compounds	•	•	•			•		
Modifier in carbon black-filled EPDM compounds			•	•	•			•
Modifier in silica-filled rubber compounds			•	•	•		•	•
Plasticizer in rubber compounds / tires	•	•	•				•	•
Polymeric chalk activator in EPDM compounds				•	•			

\* EP = Experimental Product. The indicated properties are target values and may be subject to change during the upscaling process.

## SELECTED MARKETS

### AUTOMOTIVE

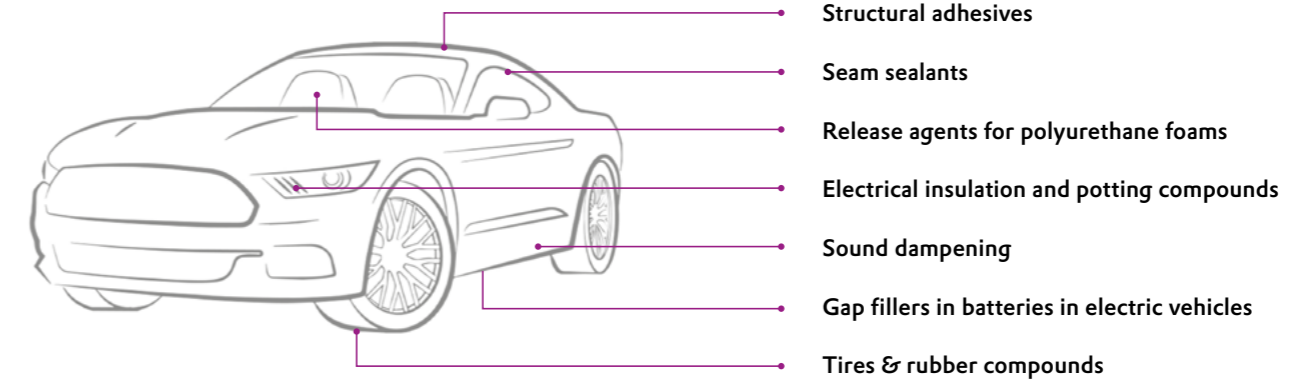

### CONSTRUCTION

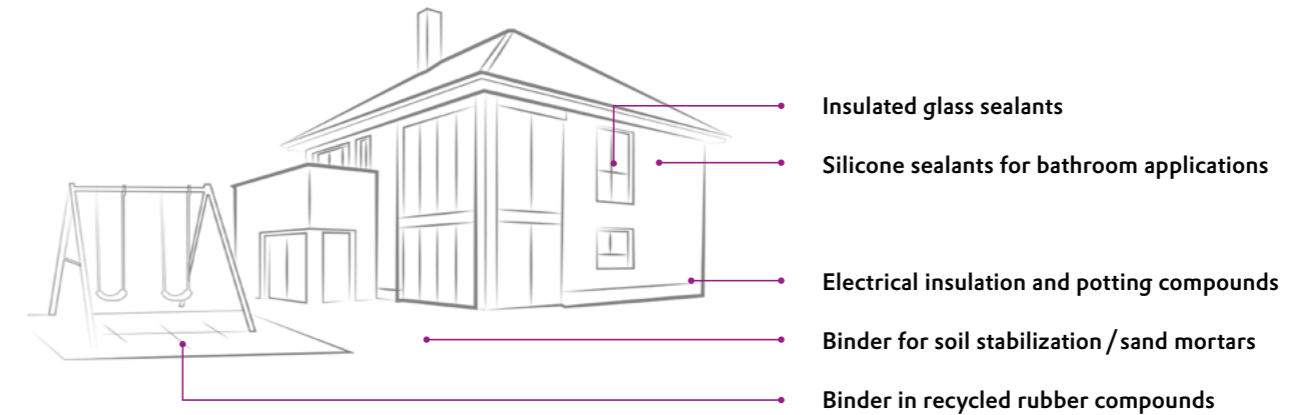

### ELECTRONICS & COMMUNICATION

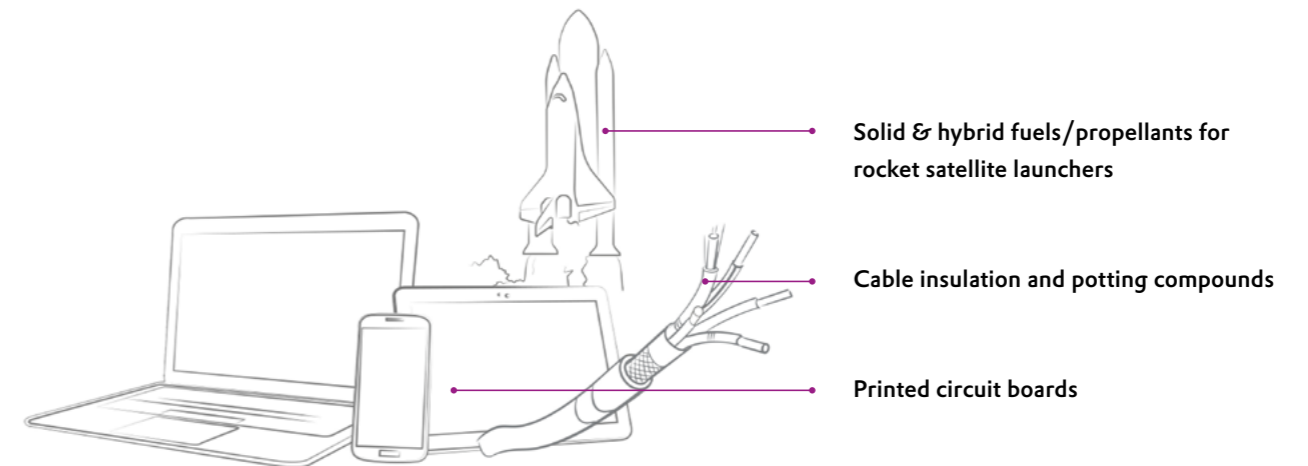

## PHYSICO-CHEMICAL PROPERTIES

### Compatibility of POLYVEST® grades with binders and resins

POLYVEST®		110	130	EP* MV	MA 75	EP* MA 100	HT	ST-E 60	EP* MAT
Acrylate resins	Methacrylates	-	-	-	-	-	-	-	-
	OH-acrylates	o	-	-	o	o	-	-	-
Alkyd resins	Short-oil	-	-	-	-	-	-	-	-
	Medium-oil	o	-	-	o	o	-	-	-
	Long-oil	o	-	-	+	+	o	o	o
Carbamic acid resins	-	-	-	-	-	-	-	-	-
Cellulose esters	-	-	-	-	-	-	-	-	-
Epoxy resins, low molecular weight	-	-	-	o	o	-	-	-	-
Glycerol resin esters	-	-	-	o	o	-	-	-	-
Hydrocarbon resins	+	+	+	o	o	+	+	+	+
Ketone resins	o	o	o	o	o	o	o	o	o
Melamine resins	-	-	-	o	o	-	-	-	-
Nitrocellulose	-	-	-	-	-	-	-	-	-
Phthalate resins	-	-	-	-	-	-	-	-	-
Resols, unplasticized	-	-	-	-	-	-	-	-	-
Rosin esters	+	+	+	+	+	+	+	+	+
Rosin-modified phenolic resins	-	-	-	-	-	-	-	-	-
Saturated polyesters	-	o	o	-	-	-	-	-	-
Styrene-alkyd resins	-	-	-	-	-	-	-	-	-
Urea resins, unplasticized resins	-	-	-	o	o	-	-	-	-
Zinc resinates	+	+	+	+	+	+	+	+	+

### Solubility of POLYVEST® grades

POLYVEST®		110	130	EP* MV	MA 75	EP* MA 100	HT	ST-E 60	EP* MAT
Alcohols		-	-	-	o	o	-	-	-
Aliphatic hydrocarbons		+	+	+	+	+	+	+	+
Aromatic hydrocarbons		+	+	+	+	+	+	+	+
Esters		o	o	o	o	o	o	o	o
Ethers		+	+	+	+	+	+	+	+
Glycol ethers		-	-	-	-	-	-	-	-
Ketones		o	o	o	o	o	o	o	o

+ compatible / soluble    o limited compatibility / solubility    - incompatible / insoluble

The compatibility results represent 40 wt.% of the binder / resin with POLYVEST®.

The solubility reflects adding 90 and 50 wt.% of solvent to 10 and 50 wt.% POLYVEST®.

This information is based on our best knowledge and experience. We recommend conducting your own tests and experiments prior to use.

\* EP = Experimental Product. The indicated properties are target values and may be subject to change during the upscaling process.

### Curing and chemical modification of POLYVEST® grades

POLYVEST®	110	130	EP* MV	MA 75	EP* MA 100	HT	ST-E 60	EP* MAT
<b>Curing via</b>								
Sulphur vulcanisation	•	•	•	•	•	•	•	•
Peroxides			•					•
Oxidative drying	•	•		•	•			
UV Curing			•					•
<b>Curing and modification via reaction with</b>								
Amines				•	•			
Carboxylic acids or anhydrides						•	•	
Polyols				•	•			
Isocyanates						•	•	

\* EP = Experimental Product. The indicated properties are target values and may be subject to change during the upscaling process.

## GENERAL INFORMATION & PRODUCT SAFETY

### GENERAL INFORMATION

Liquid polybutadiene based POLYVEST® is a non-hazardous material and is therefore not labelled according to GHS regulations. For details consult the respective product material safety data sheet.

POLYVEST® does comply with REACH regulations and is listed on or in compliance with many chemical inventories.

POLYVEST® does comply with many additional regulations. Documents will be provided upon request.

### STORAGE

POLYVEST® products are stable for at least 1 year with exclusion of air, light and moisture and at storage temperatures below 25°C.

### SAFETY & HANDLING

POLYVEST® products react with atmospheric oxygen to form peroxides and undergo crosslinking in its presence. Thus, POLYVEST® products are packed and delivered under a blanket of inert gas (nitrogen). When handling, prevent any exposure of the products to atmospheric oxygen. Opened containers should be blanketed with inert gas again and closed tightly. Please refer to our material safety data sheets.



**DISCOVER OUR  
GLOBAL NETWORK**

Find your regional contact:  
[www.evonik.com/adhesive-resins-contacts](http://www.evonik.com/adhesive-resins-contacts)

**Evonik Operations GmbH**  
Coating & Adhesive Resins  
Paul-Baumann-Straße 1  
45764 Marl  
Germany  
Phone +49 2365-49-4843  
[www.evonik.com/adhesive-resins](http://www.evonik.com/adhesive-resins)

**Evonik Corporation**  
299 Jefferson Road  
Parsippany, NJ 07054-0677  
USA  
Phone +1 973 929-8000  
Fax +1 973 929-8013

**Evonik Specialty Chemicals  
(Shanghai) Co., Ltd.**  
55 Chundong Road  
Xinzhuang Industry Park  
Shanghai, 201108, PR China  
Phone +86 21 6119-1028  
Fax +86 21 6119-1254

**POLYVEST®** is a registered trademark of Evonik Industries AG or one of its subsidiaries.

This information and all further technical advice are based on our present knowledge and experience. However, it implies no liability or other legal responsibility on our part, including with regard to existing third party intellectual property rights, especially patent rights. In particular, no warranty, whether express or implied, or guarantee of product properties in the legal sense is intended or implied. We reserve the right to make any changes according to technological progress or further developments. The customer is not released from the obligation to conduct careful inspection and testing of incoming goods. Performance of the product described herein should be verified by testing, which should be carried out only by qualified experts in the sole responsibility of a customer. Reference to trade names used by other companies is neither a recommendation, nor does it imply that similar products could not be used.

07/2022/e/hg

**We design polymers.**